

	<h1 style="margin: 0;">Sampler Specification</h1>	Specification Number	1216A-600
		Revision	01

Part No. 1216A-600
Description Powder Trier 600mm
Material of Construction: 316 stainless steel

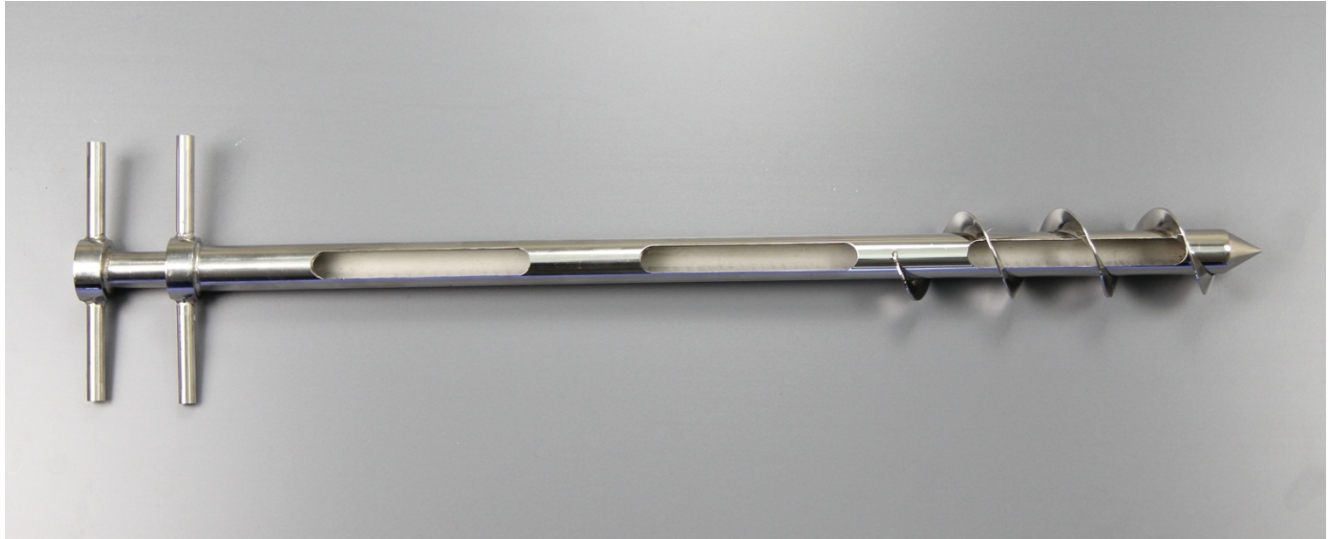

Outer Diameter of Outer Tube: 25mm
Inner Diameter of Inner Tube: 17mm
Overall Length: 650mm
Slot Length: 120mm
Number of Slots 3
Slot Positions:

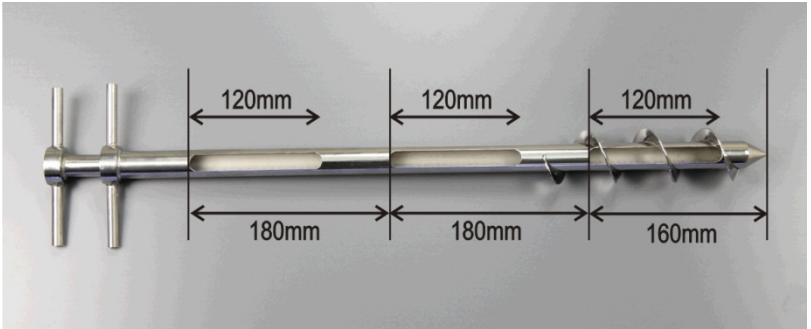

External Polish: <1 Micron Ra
Internal Polish: None
Nominal Weight of Sampler: 1306g

Specification Approved By:	Signature: 	Name: Jonathan Fenner Position: Director Date: 29-Jan-13
----------------------------	--	--